

## CUBE 120kWh, 140kWh Outdoor energy storage all-in-one



Waterproof IP55



Wifi Real-time control



APP control

### Product introduction

CUBE BOX120/140 features a modular design, combining lithium iron phosphate batteries, racks, BMS, PCS, air-conditioning, temperature control, fire detection, and automatic extinguishing. It boasts safety, reliability, rapid deployment, cost-efficiency, high energy efficiency, and intelligent management.

### Product Features



Exquisite craftsmanship  
Higher specific energy,  
more environmentally friendly.



Safe and reliable  
Longer cycle life.



Integrated design  
Convenient installation and  
higher efficiency.



Smart and friendly  
WiFi remote Monitoring  
(optional)



Remote Monitoring  
Self-developed APP



Smart BMS  
Big Power Smart BMS



Full Bracket Design  
Full space for each  
cell's best performance

# 120kWh 140kWh Energy Storage Battery, Outdoor energy storage all-in-one machine

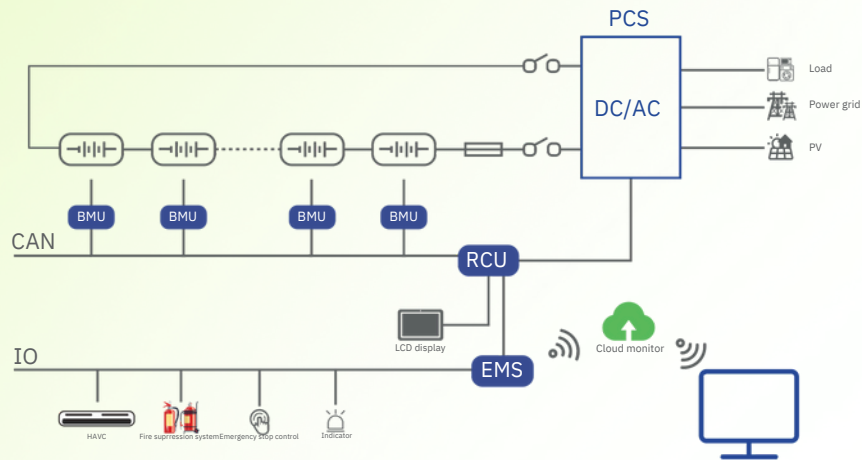

## Function Parameters

Model No.	CUBE 120-50	CUBE 140-50
Nominal Energy	122.8KWH	143.2KWH
Nominal Voltage	614V	716V
Nominal Capacity	200Ah	200Ah
Cell Type	LFP	LFP
Standard Charge Voltage	691V	806V
Max Charge Current	200A	200A
Discharge Cut-Off Voltage	537V	627V
Max Discharge Current	200A	200A
Maximum working altitude	≤2000m	
Working humidity range	5-85%RH (no condensation)	
Cooling method	Air-cooled	
Cycle Life *	25±2°C/0.2C/80%≥6000	
Range of working temperature	-10 ~ 60°C	
Fire Fighting System	Aerosol	
Certification	Cell:UL1642 / IEC62619 / CE / ROHS / MSDS / UN38.3 Pack: MSDS / UN38.3	
Weight	≈1.2T	≈1.4T
Dimensions	2000*1082*1676.5mm	
Battery system	BMS management system, fire protection system, air-cooled unit, cabinet, PCS system	