

CUBE 61kWh 71kWh Outdoor energy storage all-in-one machine



Weatherproof IP55



Wifi Real-time control



APP control

Product introduction

CUBE BOX61/71 features a modular design, combining lithium iron phosphate batteries, racks, BMS, PCS, air-conditioning, temperature control, fire detection, and automatic extinguishing. It boasts safety, reliability, rapid deployment, cost-efficiency, high energy efficiency, and intelligent management.

Product Features



Exquisite craftsmanship
Higher specific energy,
more environmentally friendly.



Safe and reliable
Longer cycle life.



Integrated design
Convenient installation and
higher efficiency.



Smart and friendly
WiFi remote Monitoring
(optional)



Remote Monitoring
Self-developed APP



Smart BMS
Big Power Smart BMS



Full Bracket Design Full
space for each
cell's best performance

61kWh 71kWh Energy Storage Battery, Outdoor energy storage all-in-one machine

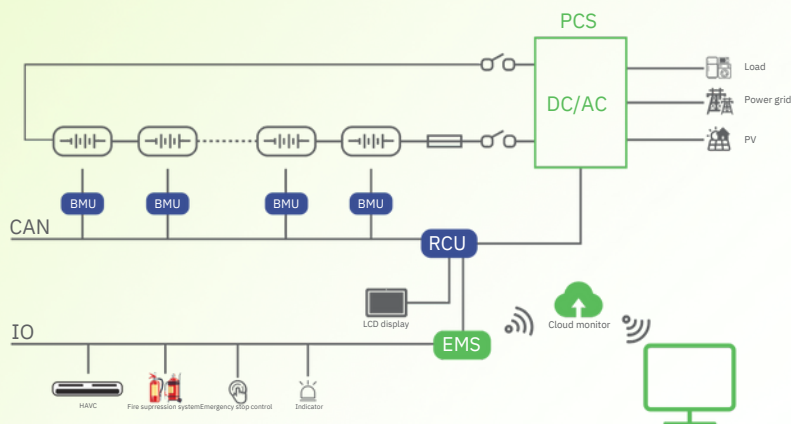

Function Parameters

Model No.	CUBE 61-50	CUBE 71-50
Nominal Energy	61KWH	71KWH
Nominal Voltage	614.4V	716.8V
Nominal Capacity	100Ah	100Ah
Cell Type	LFP	LFP
Standard Charge Voltage	691.2V	806.4V
Max Charge Current	100A	100A
Discharge Cut-Off Voltage	556.8V	645V
Max Discharge Current	100A	100A
Maximum working altitude	2000m	
Working humidity range	≤95% (no condensation)	
Cooling method	Air-cooled	
Cycle Life *	25±2°C/0.2C/80%≥6000	
Range of working temperature	-20 ~ 50°C	
Fire Fighting System	Aerosol	
Certification	Cell:UL1642 / IEC62619 / CE / ROHS / MSDS / UN38.3 Pack: MSDS / UN38.3	
Dimensions	1066mm*1174mm*1561mm	
Weight	≈780kg	≈850kg
Warranty	10 years	
Battery system	BMS management system, fire protection system, air-cooled unit, cabinet, PCS system	